

Electrode Holder

# HY-ER3

## INSTRUCTION MANUAL

Thank you for purchasing HANYOUNG product.  
Please check whether the product is the exactly same as you ordered.  
Before using the product, please read this instruction manual carefully.  
Please keep this manual where you can view at any time

HEAD OFFICE

HANYOUNGNUX CO.,LTD  
28, Gilpa-ro 71beon-gil, Nam-gu, Incheon, Korea  
TEL : (82-32)876-4697 FAX : (82-32)876-4696  
http://www.hynux.net

INDONESIA FACTORY

PT. HANYOUNG ELECTRONIC INDONESIA  
JL.CEMPAKA BLOK F 16 NO.02 DELTA SILICON II  
INDUSTRIAL PARK LIPPO CIKARANG  
CICAU, CIKARANG PUSAT, BEKASI INDONESIA 17550  
TEL : 62-21-8911-8120~4 FAX : 62-21-8911-8126

HANYOUNG NUX



### Safety information

Before using the product, please read the safety information thoroughly and use it properly. Alerts declared in the manual are classified to Danger, Warning and Caution by their criticality

<b>⚠ DANGER</b>	DANGER indicates an imminently hazardous situation which, if not avoided, will result in death or serious injury
<b>⚠ WARNING</b>	WARNING indicates a potentially hazardous situation which, if not avoided, could result in death or serious injury
<b>⚠ CAUTION</b>	CAUTION indicates a potentially hazardous situation which, if not avoided, may result in minor or moderate injury

#### ⚠ Warning

- To prevent deflection or malfunction of this product, supply proper power voltage in accordance with the rating.
- If there is a possibility of an accident caused by errors or malfunctions of this product, install external protection circuit to prevent the accident.

#### ⚠ Caution

- Distilled or dirty water containing oil, such as conductive liquid, it can not be used.
  - Flammable liquids such as gasoline, kerosene, fuel oil, etc., can not be used.
  - In case of using electrode in outdoor, please avoid using at splashing water, many dust. It may cause malfunction.
  - Please clean the electrode after 6 months from installation. Subsequently cleaning 1-2 times a year.
  - Please install the electrodes E1, E2, E3 with a significant difference in the length.
  - Please install the electrodes only vertically.
  - Please do not install the unit in a place of severe vibration or shock.
  - Please shorten the wiring length between the unit and the electrode as a thick wire.
  - In order to prevent contact of the electrodes in Water tank, please keep each electrodes the distance as 1 meter.
  - Please do not insert the electrode wiring and power lines in the same duct. Please separate wiring may cause malfunction due to induction.
  - If you bury the wire in the ground it may cause the malfunction due to the stray capacitance. Please insulate the wire firmly.
- ※ Please follow the above contents described in the safety information if not it may lead to a product failure.

### Connection diagram

#### ■ External connection (FS-3A)

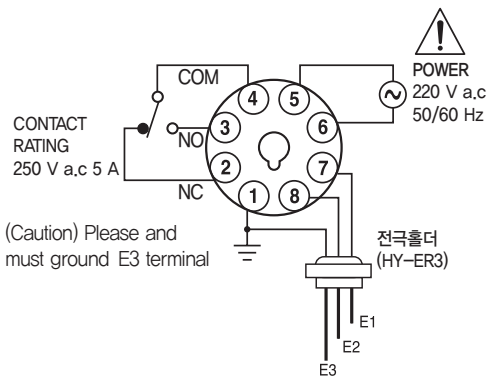

#### ■ Internal connection (FS-3A)

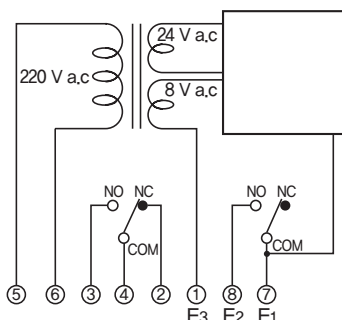

### Dimension

[Unit : mm]

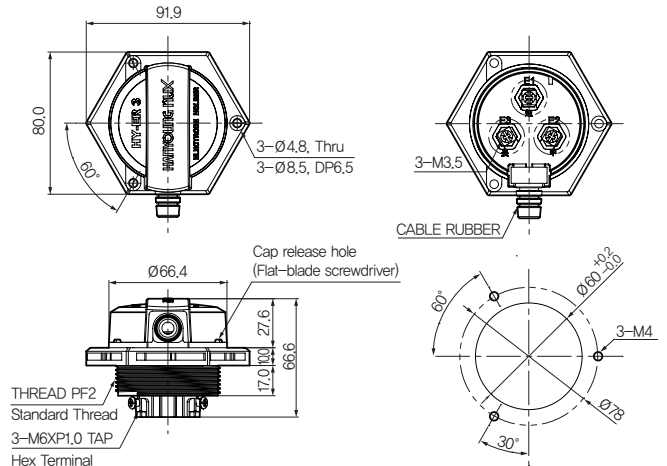

### Using the example

#### ■ Example of Water Supply connection (FS-3A)

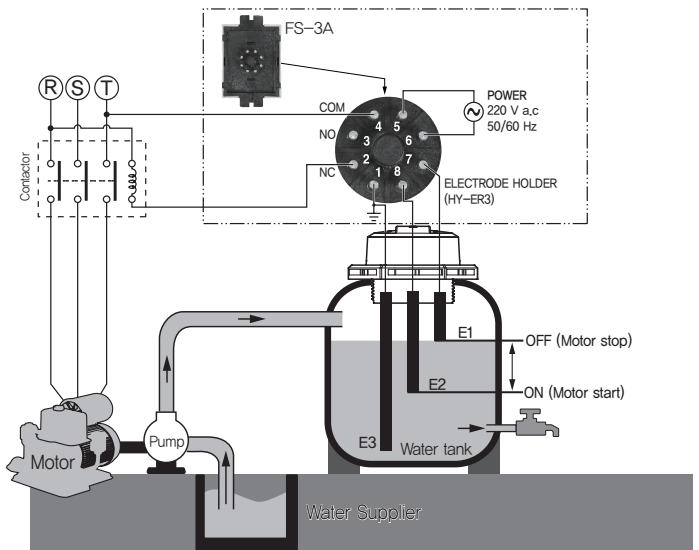

#### ■ Example of Drain connection (FS-3A)

